

sales order 5274		Custom Surface Mounted Bench	Date 09-10-12
item 0000		No. RF-B-0019-72	scale 3/32"=1"
finish	TBD	<input type="checkbox"/> approved <input type="checkbox"/> approved as noted <input type="checkbox"/> not approved revise as noted	
PHONE 540.342.1548 FAX 540.342.1417 WEB RCLFING.COM			

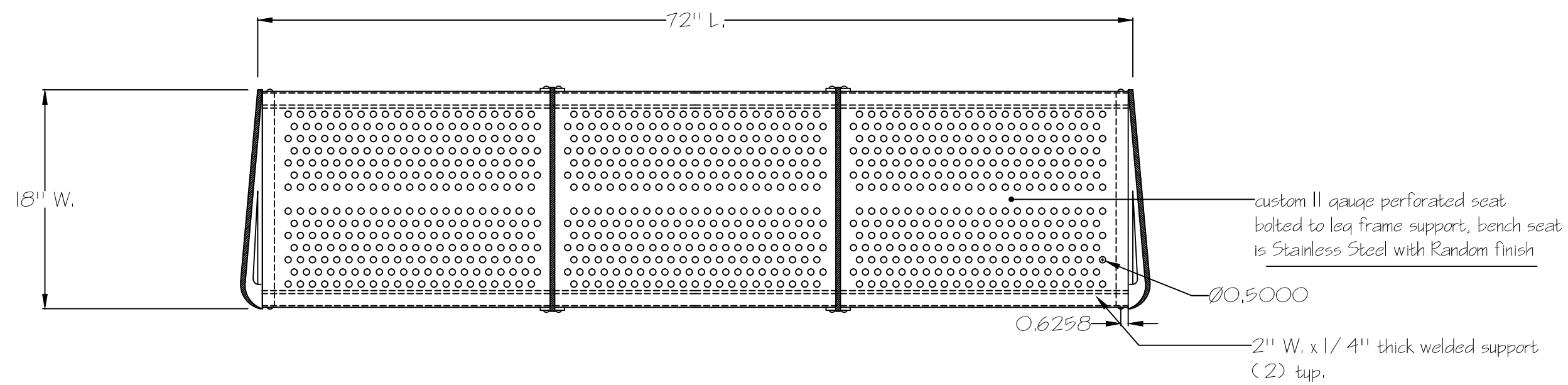

Top View



- \* custom punched seat
- \* custom laser cut details
- \* bench is bolted to floor
- \* revised 10-03-12

Front View

side and frame will be mild steel with aluminum texture finish or acceptable match

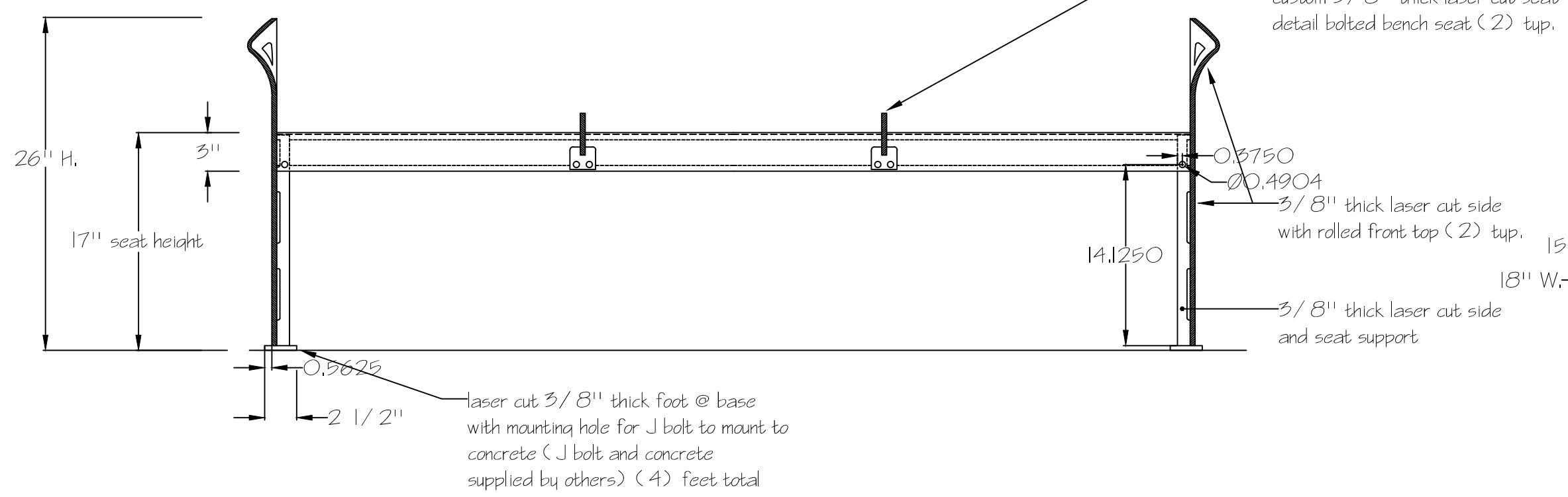

Side View

