

sales order 4205	
item ?????	
finish	TBD

approved  
 approved as noted  
 not approved revise as noted

authorized signature \_\_\_\_\_ date \_\_\_\_\_

**Custom Bench**  
 No. RF-B-0005-72 (nch)  
 Date 05-27-11  
 Scale 3/32" = 1"  
 PHONE 540.342.1548 FAX 540.342.1417  
 WEB RCLFING.COM



top view of bench (back and sides omitted for clarity)

\* custom laser cut details (thickness TBD by FAB manager)  
 \* revised 06-08-11

Plan View

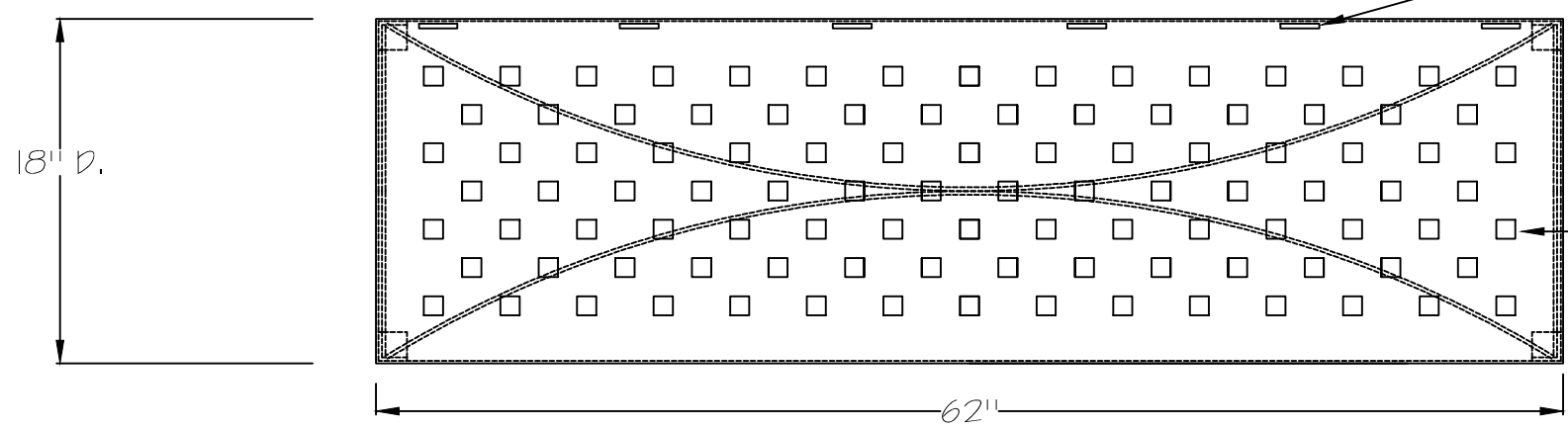

slots for back  
 (actual size TBD)

custom laser cut bench with  
 1" square hole openings  
 and 2 1/2" return on each side  
 (metal thickness TBD by fab)

Front View

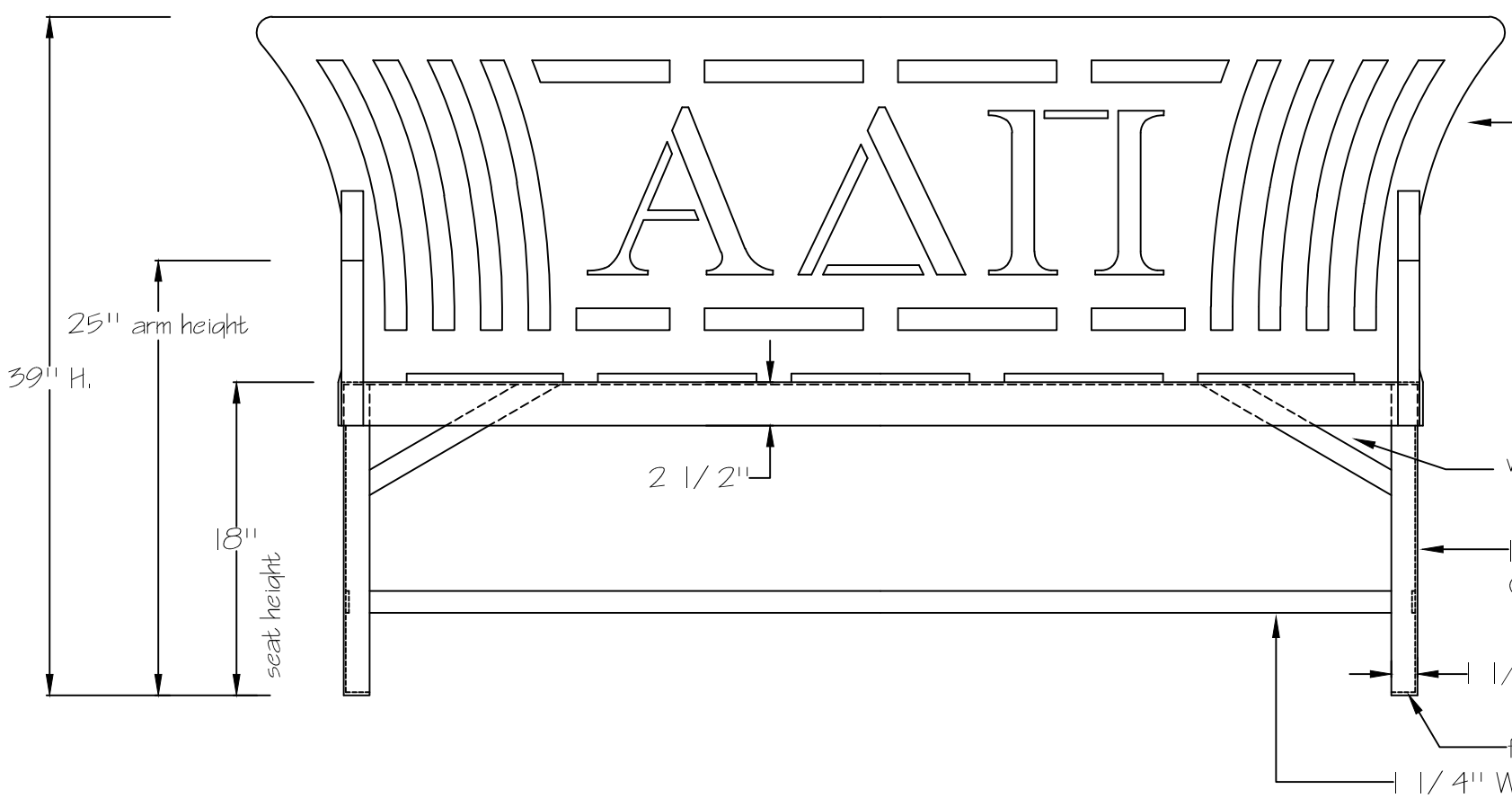

custom laser cut back welded to  
 bench seat (actual thickness TBD by FAB)

welded support (2) typ.

1/2" W. x 3/16" thick angle iron leg  
 (4) typ.

1/2"

flat bottom welded foot (4) typ.

1/4" W. arc support (see plan view)

Side View

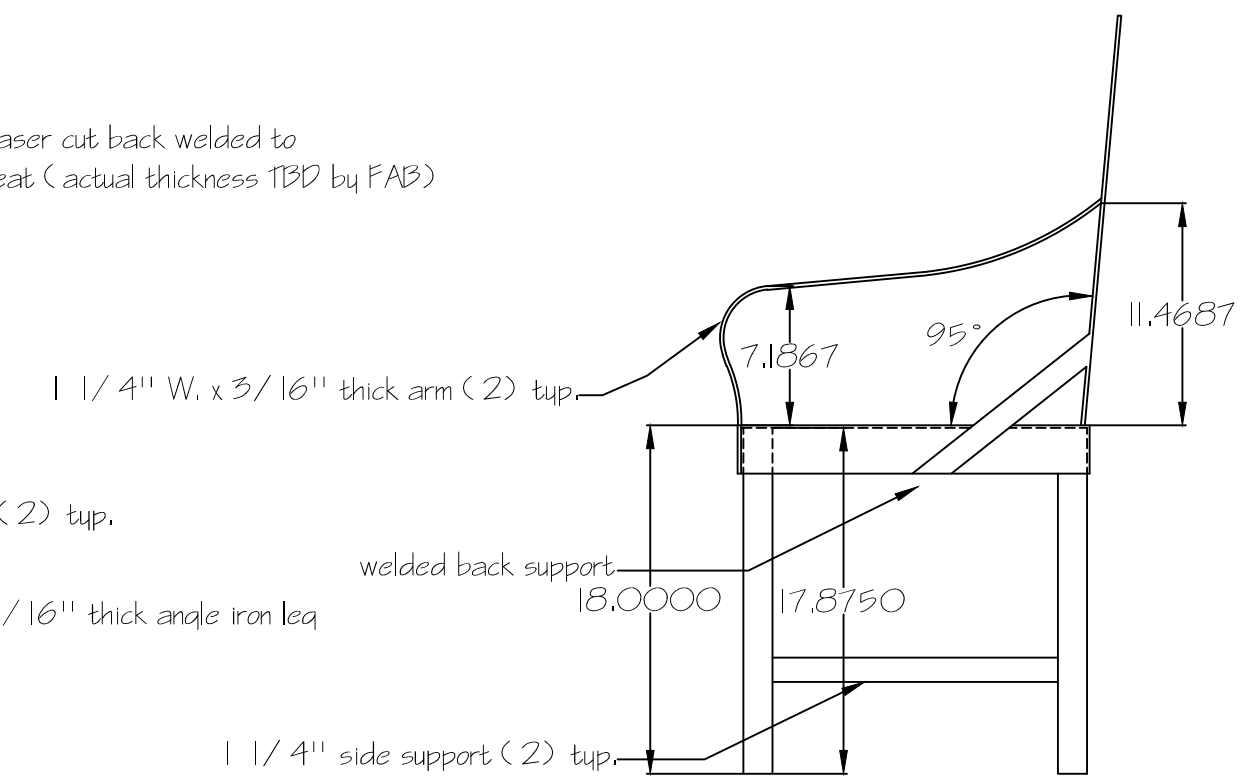

1 1/4" W. x 3/16" thick arm (2) typ.

welded back support  
 18.0000

17.8750

1 1/4" side support (2) typ.